



# **YDLIDAR TX20 DATASHEET**

DOC#: 01.13.004200

## CONTENTS

---

overview.....	2
Product Features.....	2
Applications.....	2
Installation and dimensions.....	2
Specifications.....	3
Product Parameter.....	3
Electrical Parameter.....	3
Interface Definition.....	3
Data communication.....	4
Optical Characteristic.....	4
Polar coordinate system definition.....	5
Others.....	6
Development and support.....	6
Revision.....	6

## OVERVIEW

YDLIDAR TX20 is a 360-degree two-dimensional rangefinder (hereinafter referred to as TX20) developed by YDLIDAR team. Based on the principle of TOF, it is equipped with related optics, electricity, and algorithm design to achieve high-frequency and high-precision distance measurement. The mechanical structure rotates 360 degrees to continuously output the angle information as well as the point cloud data of the scanning environment while ranging.

## Product Features

- 360 degree omnidirectional scanning ranging distance measurement
- Small distance error, stable performance and high accuracy
- 20 m Ranging distance
- Strong resistance to ambient light interference
- Low power consumption, small size and long lifespan
- Laser power meets Class I laser safety standards
- Motor speed support customization

## Applications

- Robot navigation and obstacle avoidance
- Robot ROS teaching and research
- Regional security
- Environmental scanning and 3D reconstruction
- Commercial robot /Robot vacuum cleaner

## Installation and dimensions

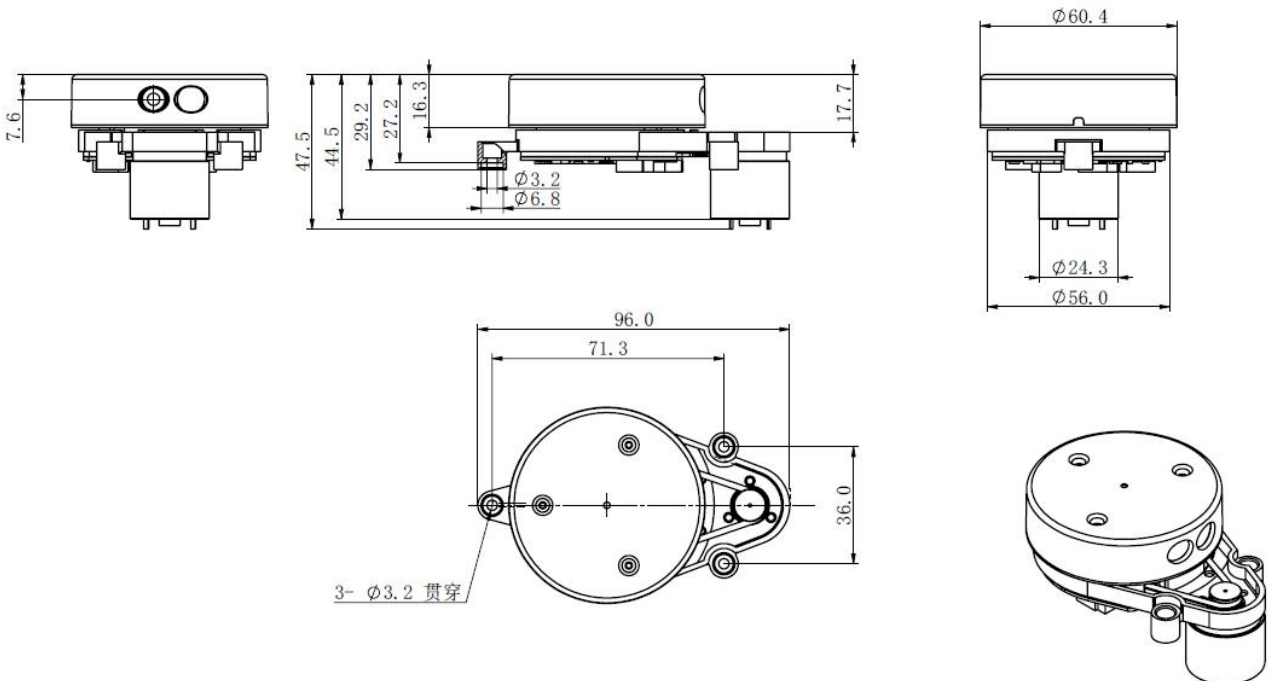

FIG 1 YDLIDAR TX20 INSTALLATION SIZE

## SPECIFICATIONS

### Product Parameter

CHART1 YDLIDAR TX20 PRODUCT PARAMETER

Item	Min	Typical	Max	Unit	Remarks
Ranging frequency	-	4000	-	Hz	4000 times per second
Ranging distance	0.1	-	20	m	80% reflectivity
Scanning angle	-	0~360	-	Deg.	-
Motor frequency	5	7	12	Hz	
Ranging accuracy	-	+/-4cm	-	-	
Angle resolution		0.63		Deg.	Motor frequency=7Hz

*Note 1: The measurement range and relative accuracy above are the factory inspection standard value;*

*Note 2: Please avoid using Lidar under high-temperature, high-low temperature or strong vibration situation, which might cause a 3% relative error.*

### Electrical Parameter

CHART2 YDLIDAR TX20 ELECTRICAL PARAMETER

Item	Min	Typical	Max	Unit	Remarks
Supply voltage	4.8	5	5.2	V	Excessive voltage might damage the Lidar while low affect normal performance
Voltage ripple	0	50	100	mV	Excessive ripple affect normal performance
Starting current	200	300	400	mA	Higher current required at start-up
Working current	200	350	380	mA	System work, motor rotation

### Interface Definition

TX20 provides a PH1.25-4P female connector with functional interfaces for system power, data communication and motor control.

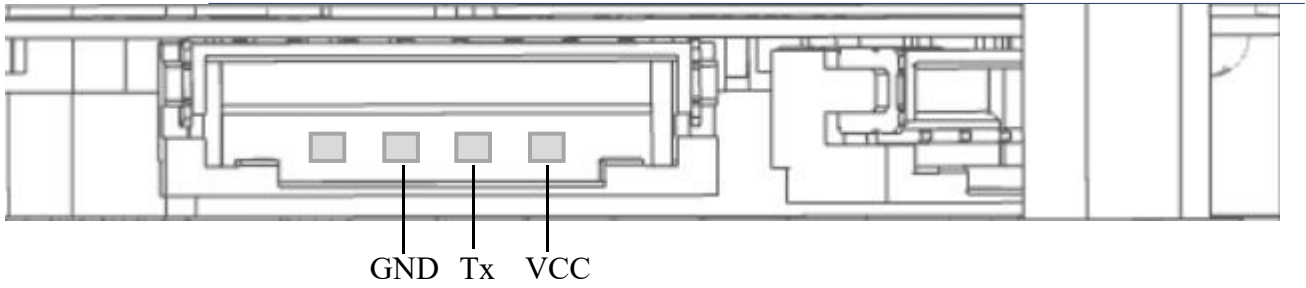

FIG2 TX20 INTERFACES

**CHART3 YDLIDAR TX20 INTERFACE DEFINITION**

Pin	Type	Description	Defaults	Range	Remarks
VCC	Power Supply	Positive	5V	4.8V~5.2V	-
Tx	Output	System serial output	-	-	Data stream: Lidar → Computer
GND	Power Supply	Negative	0V	0V	-

**Data communication**

With a 3.3V level serial port (UART), users can connect the external system and the product through the physical interface. After that, you can obtain the real-time scanned point cloud data, device information as well as device status. The communication protocol of parameters are as follows:

**CHART4 YDLIDAR TX20 SERIAL SPECIFICATION**

Item	Min	Typical	Max	Unit	Remarks
Baud rate	-	115200	-	bps	8-bit data bit,1 stop bit, no parity
High Signal Level	1.8	3.3	3.5	V	Signal voltage>1.8V
Low signal Level	0	0	0.5	V	Signal voltage<0.5V

**Optical Characteristic**

TX20 uses an infrared point pulsed laser that meets FDA Class I laser safety standards. The laser and optical lens are used for the transmission and reception of the laser signal to achieve high- frequency ranging while working. To ensure system ranging performance, please keep the laser and optical lens clean. The detailed optical parameters are as follows:

**CHART6 YDLIDAR TX20 LASER OPTICAL PARAMETERS**

Item	Min	Typical	Max	Unit	Remarks
Laser wavelength	895	905	915	nm	Infrared band
Laser power	-	15	25	W	Transient power
FDA	⚠ Class I				

**Polar coordinate system definition**

For secondary development, TX20 internally defines a polar coordinate system.

Pole: the center of the rotating core of the TX20;

Positive direction: clockwise;

Zero angle: directly in front of the TX20 motor;

A +/-3° deviation exists as shown because of the model type,

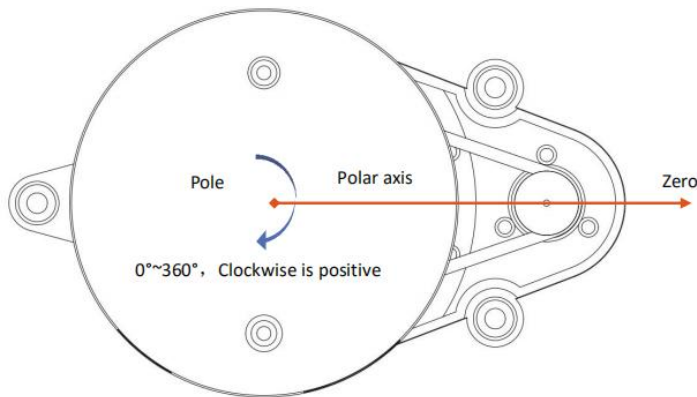

FIG4 YDLIDAR TX20 POLAR COORDINATE SYSTEM DEFINITION

**Others**

**CHART7 YDLIDAR TX20 OTHERS**

Item	Min	Typical	Max	Unit	Remarks
Operating temperature	0	20	40	°C	High temperature environment will reduce life expectancy
Lighting environment	0	80000	100000	Lux	For reference only
Weight	-	100	-	g	N.W.

**Development and support**

With a wealth of hardware and software interfaces, TX20 can support motor enable control, speed control, and enable scanning.

Also, the 3D model is available. YDLIDAR provides the graphical debugging client -Point Cloud Viewers, together with the corresponding SDK development kit and ROS development kit.

For the TX20 development manual, SDK development manual and ROS manual, please download from our official website: [www.ydlidar.com](http://www.ydlidar.com)

ROS: [https://github.com/YDLIDAR/ydlidar\\_ros/tree/T4](https://github.com/YDLIDAR/ydlidar_ros/tree/T4)

SDK: <https://github.com/YDLIDAR/sdk/tree/T4>

(Note: Please choose **TS2** model when you open the client software.)

**Revision**

Date	Version	Contents
2019-04-30	1.0	First written
2019-12-02	1.1	Delete Motor speed control adjustable part. Modify the size and laser power parameters. Correct the ranging error and the lighting environment parameters.